

TECHNICAL DATA SHEET

PRESTO®

Range: PRESTO LINEA®

Ref: 57212 - Deck-mounted sensor mixer tap for washbasin, battery, 3l/min with stop valve

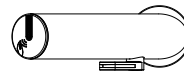
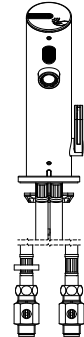
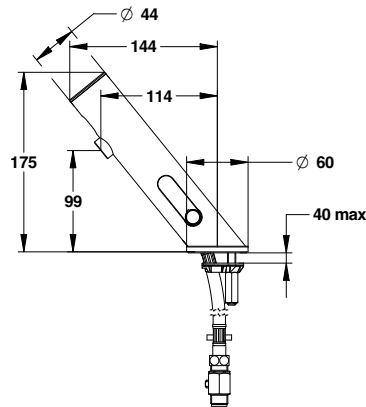

> Working pressure:

- 1 to 5 bar

> Function:

- Starts and stops automatically by hand detection
- Sensor trigger suitable for PRM, elderly, children and disabled people

> Flow:

- 3l/min at 3 bar with integrated regulated anti-limescale aerator

> Hydraulic supply:

- F G 3/8" (12x17) hoses

> Power supply:

- Integrated 3V CR123A lithium batteries (x2)

> Material and colour finish:

- Chrome-plated brass body with smooth inside body
- Chrome-plated molded metal cover

> Thermal resistance:

- Resistant to a temperature of 75°C for 30-minute-thermal-shocks

> Security:

- Anti-overflow security time set to 30 seconds preventing the water to flow continuously
- Automatic shutdown of solenoid valve in case of low battery or sensor damage
- Duty flush 30 sec every 24h after last use (adjustable flow time and frequency)
- Low battery alert (blinking led light)
- Maximum temperature limitation with adjustable temperature stop

> Installation:

- Recommended installation : 30 cm minimum between the sensor and the basin

> Delivered with:

- 1 Brass clamping nut, 1 Gasket and 1 Washer
- 2 PEX hoses with revolving nuts, NF check valves and filter gaskets
- 2 M M G 3/8" (12x17) stop valves
- 1 Self-adhesive sticker
- 1 Instruction manual

> Standards & approvals:

- Brass body in accordance with NF EN1982, EN12164, NF EN 12165,
- UBA list compliant
- 200-hour neutral salt spray resistant (NSS) in accordance with NF ISO 9227

Ce document n'est pas contractuel ; nous nous réservons le droit de modifier les caractéristiques de nos produits sans préavis. Toutes nos marques et tous modèles sont déposés.

